

Potable water valve cones



J.A Harrison are a renowned UK manufacturer, offering complete sealing solutions. Now available, valve packing cones along with other associated products for the Water Industry.

Method of sealing potable water rising stem valves where a conventional braided stuffing box packing has been previously used

- EPDM rubber.
- WRAS approved for potable water
- Replaces the need for packing
- Extremely durable with long service life
- Not affected by high usage
- Dual sealing action against stem and gland follower
- Simply remove packing, insert correct sized cone, invert the gland follower and bolt down
- Extensively used by Water Authorities.



J.A. Harrison

Complete Sealing Solutions

Potable water valve cones

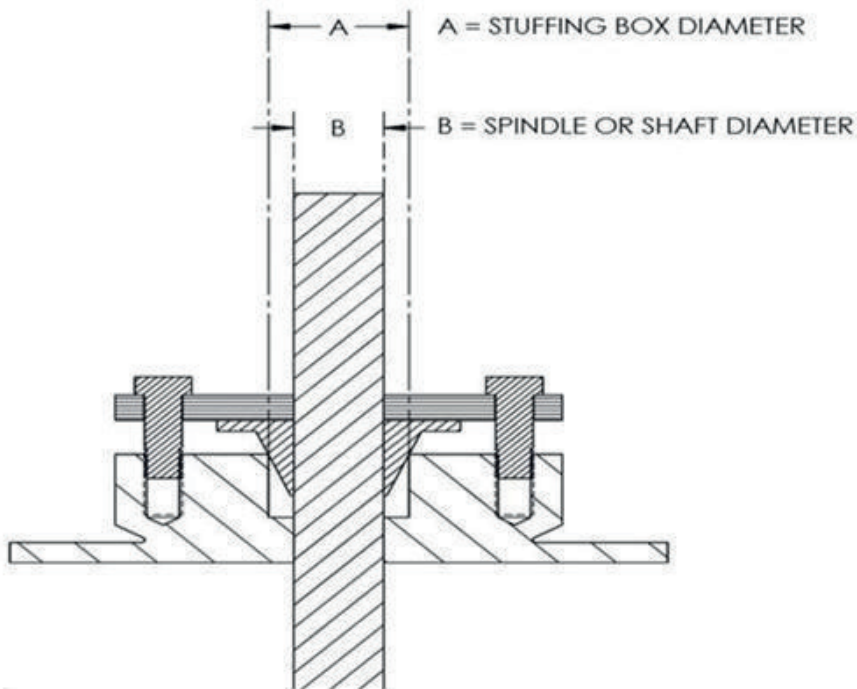

A Valve Stem Diameter		B Stuffing Box I/D		Cone Number
25mm	1"	43mm	1 ¾"	No 6
28mm	1 1/16"	50mm	2"	No 8
31mm	1 ¼"	55mm	2 3/16"	No 10
34mm	1 3/8"	60mm	2 3/8"	No 12
38mm	1 ½"	63mm	2 ½"	No 14
40mm	1 9/16"	65mm	2 9/16"	No 16
44mm	1 ¾"	69mm	2 5/8"	No 18



J.A. Harrison

Complete Sealing Solutions